

Introduction to hyphenated techniques and their applications in pharmacy

Abstract

The hyphenated technique is developed from the coupling of a separation technique and an on-line spectroscopic detection technology. The remarkable improvements in hyphenated analytical methods over the last two decades have significantly broadened their applications in the analysis of biomaterials, especially natural products. In this article, recent advances in the applications of various hyphenated techniques, e.g., GC-MS, LC-MS, LC-FTIR, LC-NMR, CE-MS, etc. in the context of pre-isolation analyses of crude extracts or fraction from various natural sources, isolation and on-line detection of natural products, chemotaxonomic studies, chemical fingerprinting, quality control of herbal products, dereplication of natural products, and metabolomic studies are discussed with appropriate examples.

Key words: Hyphenated technique, GC-MS, LC-FTIR, natural products, separation technique

INTRODUCTION

Hyphenated techniques combine chromatographic and spectral methods to exploit the advantages of both. Chromatography produces pure or nearly pure fractions of chemical components in a mixture. Spectroscopy produces selective information for identification using standards or library spectra.

A couple of decades ago, Hirschfeld introduced the term “hyphenation” to refer to the on-line combination of a separation technique and one or more spectroscopic detection techniques.^[1] This technique, developed from a marriage of a separation technique and a spectroscopic detection technique, is nowadays known as hyphenated technique [Figure 1].

In recent years, hyphenated techniques have received ever-increasing attention as the principal means to solve complex analytical problems. The power of combining separation technologies with spectroscopic techniques has been demonstrated over the years for both quantitative and qualitative analysis of unknown compounds in complex natural product extracts or fractions. To obtain structural information leading to the identification of the compounds present in a crude sample, liquid chromatography (LC), usually a high-performance liquid chromatography (HPLC), gas chromatography (GC), or capillary electrophoresis (CE) is linked to spectroscopic detection techniques, e.g., Fourier-transform infrared (FTIR), photodiode array (PDA) UV-vis absorbance or fluorescence emission, mass spectroscopy (MS), and nuclear magnetic resonance spectroscopy (NMR), resulting in the introduction of various modern hyphenated techniques, e.g., CE-MS, GC-MS, LC-MS, and LC-NMR. HPLC is the most widely used analytical separation technique for the qualitative and quantitative determination of compounds in natural product extracts. The physical connection of HPLC and MS or NMR has increased the capability of solving structural problems of complex natural products. Because of the greater sensitivity, LC-MS has been more extensively used than LC-

**Kalpesh N Patel,
Jayvadan K Patel,
Manish P Patel,
Ganesh C Rajput,
Hitesh A Patel**

Nootan Pharmacy College,
Kamana Crossing,
Visnagar - 384 315, India

Address for correspondence:

Dr. Kalpesh N Patel,
Nootan Pharmacy College,
Kamana crossing,
Visnagar - 384 315, India.
E-mail: coolkalpesh_77@
yahoo.co.in

DOI: 10.4103/2229-4708.72222

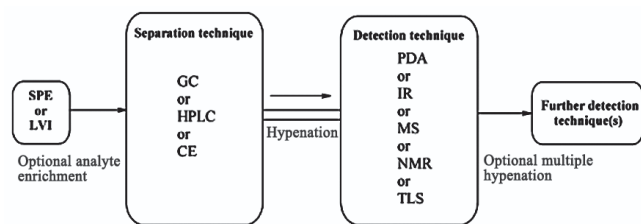

Figure 1: Hyphenated technique

NMR. The hyphenation does not always have to be between two techniques; the coupling of separation and detection techniques can involve more than one separation or detection techniques, e.g., LC-PDA-MS, LC-MS-MS, LC-NMR-MS, LCPDA-NMR-MS, and the like. Where trace analysis is vital, and the analyte enrichment is essential, on-line coupling with solid-phase extraction (SPE), solid-phase microextraction or large volume injection (LVI) can be incorporated to build in a more powerful integrated system, e.g., SPE-LC-MS or LVI-GC-MS.

The two key elements in natural product research are the isolation and purification of compounds present in crude extracts or fractions obtained from various natural sources, and the unambiguous identification of the isolated compounds. Thus, the on-line characterization of secondary metabolites in crude natural product extracts or fractions demands high degree of sophistication, and richness of structural information, sensitivity, and selectivity. The development of various hyphenated techniques has provided the natural product researchers with extremely powerful new tools that can provide excellent separation efficiency as well as acquisition of on-line complementary spectroscopic data on an LC or GC peak of interest within a complex mixture. The main focus of this chapter is to provide an overview of basic operational principles of various modern hyphenated techniques and to present several literature examples of applications of these techniques. Detailed information on the principle, history, instrumentation, and methodology is available in literature.^[2-15]

AVAILABLE HYPHENATED TECHNIQUES

GC-MS

With MS as the preferred detection method, and single- and triplequadrupole, ion trap and time-of-flight (TOF) mass spectrometers as the instruments most frequently used, both LC-MS and GC-MS are the most popular hyphenated techniques in use today.^[1]

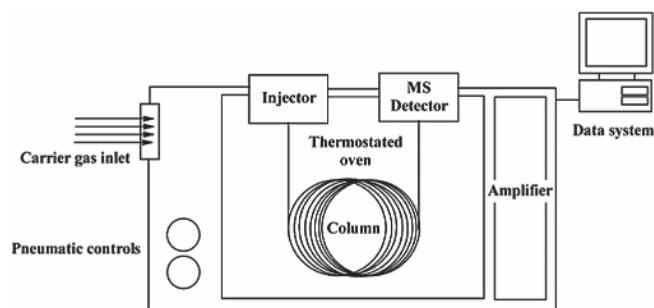

Figure 2: GC-MS

GC-MS, which is a hyphenated technique developed from the coupling of GC and MS, was the first of its kind to become useful for research and development purposes. Mass spectra obtained by this hyphenated technique offer more structural information based on the interpretation of fragmentations. The fragment ions with different relative abundances can be compared with library spectra. Compounds that are adequately volatile, small, and stable in high temperature in GC conditions can be easily analyzed by GC-MS. Sometimes, polar compounds, especially those with a number of hydroxyl groups, need to be derivatized for GC-MS analysis. The most common derivatization technique is the conversion of the analyte to its trimethylsilyl derivative. In GC-MS, a sample is injected into the injection port of GC device, vaporized, separated in the GC column, analyzed by MS detector, and recorded [Figure 2]. The time elapsed between injection and elution is called "retention time" (tR). The equipment used for GC-MS generally consists of an injection port at one end of a metal column (often packed with a sand-like material to promote maximum separation) and a detector (MS) at the other end of the column.

A carrier gas (argon, helium, nitrogen, hydrogen, to name a few) propels the sample down the column. The GC separates the components of a mixture in time and the MS detector provides information that aids in the structural identification of each component.

The GC-MS columns can be of two types: capillary columns, and macrobore and packed columns. The following points need to be considered carefully regarding the GC-MS interface.

1. The interface transports efficiently the effluent from the GC to MS.
2. The analyte must not condense in the interface.
3. The analyte must not decompose before entering the MS ion source.
4. The gas load entering the ion source must be within the pumping capacity of the MS.

The most extensively used interfaces for a GC-MS are electron impact ionization (EI) and chemical ionization (CI) modes. However, in modern GC-MS systems, various other types can be used that allow identification of molecular ion. For example, an orthogonal TOF mass spectrometry coupled with GC is used for confirmation of purity and identity of the components by measuring exact mass and calculating elemental composition. Nowadays, a GC-MS is integrated with various on-line MS databases for several reference compounds with search capabilities that could be useful for spectra match for the identification of separated components.

LC-IR

The hyphenated technique developed from the coupling of an LC and the detection method infrared spectrometry (IR) or FTIR is known as LC-IR or HPLC-IR. While HPLC is one of the most powerful separation techniques available today, the IR or FTIR is a useful spectroscopic technique for the identification of organic compounds, because in the mid-IR region the structures of organic compounds have many absorption bands that are characteristic of particular functionalities, e.g., -OH, -COOH, and so on. However, combination of HPLC and IR is difficult and the progress in this hyphenated technique is extremely slow because the hyphenated technique's 237 absorption bands of the mobile phase solvent are so huge in the mid-IR region that they often obscure the small signal generated by the sample components.

In addition, as a detection technique, IR is much less sensitive compared to various other detection techniques, e.g., UV and MS. The recent developments in HPLC-IR technology have incorporated two basic approaches based on interfaces applied in HPLC-IR or HPLC-FTIR. One is a flow-cell approach and the other is a solvent-elimination approach. The approach used with the flow cell in LC-IR is similar to that used in UV-vis and other typical HPLC detectors. In this case, absorption of the mobile phase induces the interference of the detection of sample component absorption bands, but some transparent region of the mid-IR range produces detection possibility. For example, if one uses a mobile phase of a deuterated solvent such as heavy water or perdeuterated methanol, IR can monitor many organic compounds that have C-H structures in the molecules. The solvent-elimination approach is the preferred option in most of the LC-IR operations. After the mobile phase solvent is eliminated, IR

detection is carried out in some medium that has a transparency for IR light.

Generally, KBr or KCl salts are used for the collection of sample components in the eluent, and heating up the medium before IR detection eliminates the volatile mobile phase solvents. There are two types of interfaces for the solvent-elimination approach: diffuse-reflectance infrared Fourier transform (DRIFT) approach and buffer-memory technique.^[16,17] A unified interface for GC, HPLC, and SFC hyphenation to FTIR applying IR microscopic technique is also available today.^[18]

LC-MS

LC-MS or HPLC-MS refers to the coupling of an LC with a mass spectrometer (MS) [Figure 3]. The separated sample emerging from the column can be identified on the basis of its mass spectral data. A switching valve can help make a working combination of the two techniques. A typical automated LC-MS system consists of double three-way diverter in-line with an autosampler, an LC system, and the mass spectrometer. The diverter generally operates as an automatic switching valve to divert undesired portions of the eluate from the LC system to waste before the sample enters the MS.

An LC-MS combines the chemical separating power of LC with the ability of an MS to selectively detect and confirm molecular identity. MS is one of the most sensitive and highly selective methods of molecular analysis, and provides information on the molecular weight as well as the fragmentation pattern of the analyte molecule. The information obtained from MS is invaluable for confirming the identities of the analyte molecules.

This qualitative analysis makes it possible to reconstruct an unknown compound from MS data.

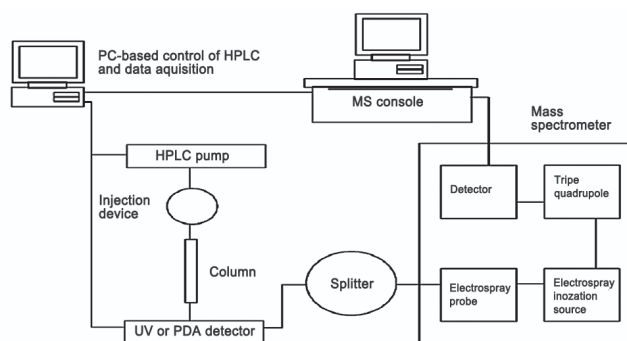

Figure 3: Schematic of an LC-MS (electrospray ionization interface) system

The ionization techniques used in LC-MS are generally soft ionization techniques that mainly display the molecular ion species with only a few fragment ions. Hence, the information obtained from a single LC-MS run, on the structure of the compound, is rather poor. However, this problem has now been tackled by the introduction of tandem mass spectrometry (MS-MS), which provides fragments through collision-induced dissociation of the molecular ions produced.^[19] The use of LC-MS-MS is increasing rapidly. Hyphenated techniques such as HPLC coupled to UV and mass spectrometry (LC-UV-MS) have proved to be extremely useful in combination with biological screening for a rapid survey of natural products.

Nowadays, various types of LC-MS systems incorporating different types of interfaces are available commercially. The interfaces are designed in such a way that they offer adequate nebulization and vaporization of the liquid, ionization of the sample, removal of the excess solvent vapor, and extraction of the ions into the mass analyzer. The two most widely used interfaces, especially in relation to natural product analysis, are electrospray ionization (ESI) and atmospheric pressure chemical ionization (APCI). The latter is considered as "the chromatographer's LC-MS interface" because of its high solvent flow rate capability, sensitivity, response linearity, and fields of applicability. With these interfaces, various types of analyzers, e.g., quadrupole, ion trap, or TOF, can be used. Each of these analyzers, however, offers varying degree of mass accuracy and resolution. In the LC-UV-MS mode, thermospray (LC-TSP-MS) and continuous-flow FAB (LC-CF-FAB) interfaces can also be applied. For phytochemical analysis, the TSP has been found to be the most suitable interface as it allows introduction of aqueous phase into MS system at a flow rate (1–2 ml/min) compatible with that usually used in phytochemical analysis.

In LC operation for LC-MS, the preferred option is a reversed-phase system using a gradient or isocratic solvent mixture of water, ACN, or MeOH. Small amounts of acetic acid, formic acid, ammonium hydroxide/ammonia solution, or ammonium acetate can also be used in the mobile phase. In conjunction with these interfaces, different types of analyzers, e.g., quadrupole, ion trap, or TOF, can be used, and they offer various degrees of mass accuracy and MS-MS possibilities. LC-MS systems do not allow a complete and unambiguous on-line identification of a component, unless it is a well-known natural product, and complementary on-line spectroscopic information

is available in databases. One of the main problems associated with LC-MS is that the quality of response strongly depends on various factors, e.g., nature of the compounds to be analyzed, the solvent and buffer used as the mobile phase, the flow rate and, of course, the type of interface used. For example, a crude natural product extract generally contains a number of various types of compounds that differ considerably in their physicochemical properties, solubilities, molecular size and stability. It is therefore extremely difficult, if not impossible, to optimize the ionization conditions that can be suitable for all those different types of compounds. One way to get around this difficulty is to analyze the extract in different ionization modes.^[10]

LC-NMR

Among the spectroscopic techniques available to date, NMR is probably the least sensitive, and yet it provides the most useful structural 240 Sarker and Nahar information toward the structure elucidation of natural products. Technological developments have allowed the direct parallel coupling of HPLC systems to NMR, giving rise to the new practical technique HPLC-NMR or LC-NMR, which has been widely known for more than last 15 years. The first on-line HPLC-NMR experiment using superconducting magnets was reported in the early 1980s. However, the use of this hyphenated technique in the analytical laboratories started in the latter part of the 1990s only. LC-NMR promises to be of great value in the analysis of complex mixtures of all types, particularly the analysis of natural products and drug-related metabolites in biofluids.

LC-NMR experiments can be performed in both continuous-flow and stop-flow modes. A wide range of bioanalytical problems can be addressed using 500, 600, and 800 MHz systems with ¹H, ¹³C, ²H, ¹⁹F, and ³¹P probes. The main prerequisites for on-line LC-NMR, in addition to the NMR and HPLC instrumentation, are the continuous-flow probe and a valve installed before the probe for recording either continuous-flow or stopped-flow NMR spectra.^[12] A UV-vis detector is also used as a primary detector for LC operation. Magnetic field strengths higher than 9.4 T are recommended, i.e., ¹H resonance frequency of 400 MHz for a standard HPLC-NMR coupling. The analytical flow cell was initially constructed for continuous-flow NMR acquisition. However, the need for full structural assignment of unknown compounds, especially novel natural products, has led to the application in the stopped-flow mode.

In fact, the benefits of the closed-loop separation-identification circuit, together with the prospect of using all presently available 2D and 3D NMR techniques in a fully automated way, have prompted the development of stopped-flow modes, e.g., time-slice mode. A typical experimental arrangement of LC-NMR is shown in Figure 4.

Generally, in LC-NMR system, the LC unit comprises autosampler, LC pump, column, and a non-NMR detector (e.g., UV, DAD, EC, refractive index, or radioactivity). From this detector, the flow is guided into the LC-NMR interface, which can be equipped with additional loops for the intermediate storage of selected LC peaks. The flow from the LC-NMR interface is then guided either to the flow-cell NMR probe-head or to the waste receptacle. Following passage through the probe-head, the flow is routed to a fraction collector for recovery and further investigation of the various fractions analyzed by NMR. An MS can also be attached to the system via a splitter at the output of the LC-NMR interface.

In most of the LC-NMR operations, reversed-phase columns are used, employing a binary or tertiary solvent mixture with isocratic or gradient elution. The protons of the solvents of the mobile phase cause severe problems for obtaining an adequate NMR spectrum. The receiver of the NMR spectrometer is not quite able to handle the intense solvent signals and the weak substance signals at the same time. To overcome this problem, solvent signal suppression can be achieved by one of the three major methods: presaturation, soft-pulse multiple irradiation or water suppression enhancement through T1 effects (WET) presaturation employing a z-gradient.^[12] This problem can also be minimized by considering the following guidelines:

1. Using eluents that have as few ¹H NMR resonances as possible, e.g., H₂O, ACN, or MeOH.
2. Using at least one deuterated solvent, e.g., D₂O (approx \$290/L), ACN-d₃ (approx \$1600/L), or MeOD (approx \$3000/L).
3. Using buffers that have as few ¹H NMR resonances as possible, e.g., TFA or ammonium acetate.
4. Using ionpair reagents that have as few ¹H NMR resonances as possible, e.g., ionpairs with *t*-butyl groups create an additional resonance.

To date, three main types of data acquisition modes have been introduced: continuous-flow acquisition, stopped-flow acquisition, and time-sliced acquisition.^[12] Whatever may be the acquisition mode,

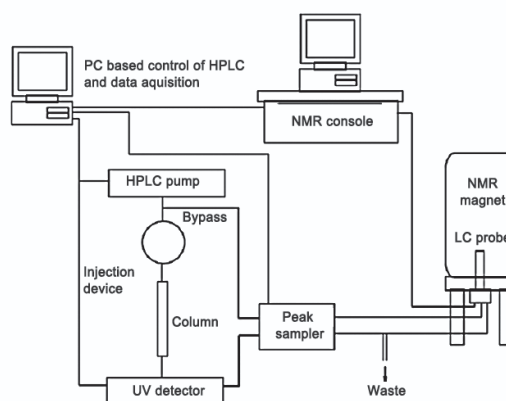

Figure 4: A typical LC-NMR system

an optimized HPLC separation is crucial to any LC-NMR analysis. As the sensitivity of LC-NMR is much less than other hyphenated techniques, e.g., LC-MS, or LC-PDA, it is imperative to develop a suitable LC separation where the quantity of the available separated compound is concentrated in the smallest available elution volume. LC-NMR represents a potentially interesting complementary technique to LC-UV-MS for detailed on-line structural analysis. Indeed, recent progress in NMR technology has given a new impulse to LC-NMR, which is now emerging as a powerful analytical tool. The development of efficient solvent suppression techniques enables the measurement of high-quality LC-¹H-NMR spectra, both on-flow and stop-flow, with reversed-phase HPLC conditions. Nondeuterated solvents such as MeOH or MeCN can be used, while water is replaced by D₂O.

Recent advances in both hardware and software for the direct coupling of LC and NMR have given a new life to this hyphenated technique. These developments include new coil and flow-cell design for high sensitivity, new RF system for multiple solvent suppression and improved dynamic range gradient elution capability, and automatic peak-picking/storing capabilities. As a result, this method is a powerful tool used in many areas such as natural products, organic molecules, biomolecules, drug impurities, by-products, reaction mixtures, and drug degradation products. The potential of HPLC-NMR for the investigation and structural elucidation of novel natural products has been enormously extended by the advent of powerful solvent suppression schemes, and their combination with a series of homo- and heteronuclear 2D NMR experiments such as 2D total correlation spectroscopy (TOCSY) or 2D nuclear Overhauser enhancement spectroscopy

(NOESY). LC-NMR, despite being known for about last two decades, has not quite become a widely accepted technique, mainly because of its lower level of sensitivity and higher cost compared to other available hyphenated techniques. However, the recent advances in technology, especially in relation to the developments in pulse field gradients and solvent suppressions methods, the improvement in probe technology, and the introduction of high-field magnets (800–900 MHz) have offered new impetus to this technique.

CE-MS

CE is an automated separation technique introduced in the early 1990s. CE analysis is driven by an electric field, performed in narrow tubes, and can result in the rapid separation of many hundreds of different compounds. The versatility and the many ways that CE can be used mean that almost all molecules can be separated using this powerful method. It separates species by applying voltage across buffer-filled capillaries, and is generally used for separating ions that move at different speeds when voltage is applied, depending on their size and charge. The solutes are seen as peaks as they pass through the detector and the area of each peak is proportional to their concentration, which allows quantitative determinations. Analysis includes purity determination, assays, and trace level determinations. When an MS detector is linked to a CE system for acquiring on-line MS data of the separated compound, the resulting combination is termed as CE-MS [Figure 5].

Separation is achieved through channels etched on the surface of the capillary (connected to an external high-voltage power supply) that delivers sample to ESIMS. This technique runs in full automation and offers high degree of sensitivity and selectivity. A new type of interface, known as coaxial sheath liquid CE-MS interface, has been developed recently, which allows the use of both LC-MS and CE-MS alternatively on the same mass spectrometer.^[20] The necessary sheath liquid is delivered by a pump that floats on the ion sprayer of the MS, avoiding any current flow toward ground. LC-MS and CE-MS modes can be switched within minutes. To obtain a stable ion spray and to avoid electrical problems, the CE power supply is used to produce the potential for the CE separation and the ESI sprayer tip simultaneously. ESIMS detection technique is generally used in most of the CE-MS systems because ESI is considered to be one of the most powerful on-line tools for the analysis of biomolecules, including natural products, providing both the

molecular weight and structural characterization of analytes.^[21] The optimization of the interfacing of CE with MS can be a real challenge because of the low flow rates (10–100 mL/min) required in CE, which is achieved by a make-up liquid.

APPLICATION OF HYPHENATED TECHNIQUES IN NATURAL PRODUCT ANALYSIS

Rapid identification and characterization of known and new natural products directly from plant and marine sources without the necessity of isolation and purification can be achieved by various modern hyphenated techniques [Figure 6]. Techniques like HPLC coupled to NMR or electrospray ionization tandem mass spectrometry (ESI-MS-MS) have been proven to be extremely powerful tools in natural product analysis, as they permit the fast screening of crude natural product extracts or fractions for detailed information about metabolic profiles, with a minimum amount of material. The combined application of various hyphenated techniques even allows the discovery of new natural product, including complete and conclusive structure elucidation, and relative configurations prior to time-consuming and costly isolation and purification

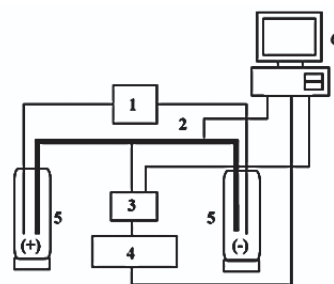

Figure 5: A typical CE-MS system. 1= High-Voltage Supply; 2= Capillary; 3= UV-vis or PDA detector; 4= MS detector; 5= Buffer solution; 6= PC control

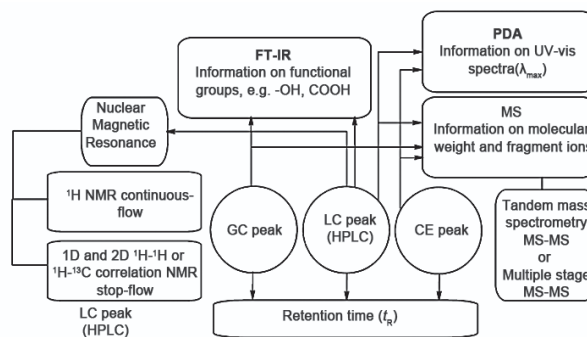

Figure 6: Summary of on-line information obtained from hyphenated techniques

process. Some examples of the application of hyphenated techniques in natural products analysis are discussed here.

Isolation and analysis of natural products

Crude natural product extracts, which represent extremely complex mixtures of numerous compounds, can be analyzed successfully by using appropriate hyphenated techniques. Among the various hyphenated techniques, LC-PDA and LC-MS are the two most extensively used for natural product analysis. LC-NMR, as well as different multiple hyphenated techniques like LC-PDA-NMR-MS have also become popular most recently. LC-MS, if the ionization technique is chosen appropriately, can be an extremely powerful and informative tool for screening crude plant extracts. The currently available various types of LC-MS systems allow the analysis of small nonpolar compounds to large polar constituents like oligosaccharides, proteins, and tannins present in natural product extracts.^[6]

Alkaloids

Alkaloids are a large group of nitrogen-containing secondary metabolites of plant, microbial, or animal origin. Various hyphenated techniques have been used in the analysis of several types of alkaloids to date. With the development and wider availability of bench-top systems, GC-MS has become the method of choice for the analysis of various pyrrolizidine and quinolizidine types of alkaloids. Quinolizidine alkaloids, the main class of alkaloids found in the family Leguminosae, have been analyzed by GC-MS recently.^[25] Most of these alkaloids are sufficiently volatile and thermostable under GC conditions to permit analysis without chemical modification. However, some hydroxylated pyrrolizidine alkaloids need to be analyzed as their trimethylsilyl derivatives. Ephedrine-type alkaloids, in dietary supplements containing the Chinese herb ma huang, were analyzed by GC-MS and GC-FTIR.

A number of protoberberine metabolites, differing in the number and the placement of various oxygen functions on the aromatic rings, have been identified prior to isolation from the *Corydalis* cell cultures by LC-NMR and LC-MS.^[26] This study provided the preliminary evidence for biosynthetic pathways to the formation of these alkaloids, especially the metabolic pathway to 2,3,10,11-oxygenated tetrahydroprotoberberines in cultured cells. An APCI interface was used in the LC-MS system, and the mass spectra were obtained with selected ion

monitoring (SIM) and total ion monitoring (TIM) in the positive ion mode. Molecular ion information was obtained on the basis of protonated molecular ion $[M + H]^+$ or a cluster ion $[M + HCF_3]^+$. The LC-NMR analysis was carried out on a Varian UNITY-INOVA-500 NMR spectrometer equipped with a PFG indirect detection LC-NMR probe with a 60 mL flow cell, using stop-flow mode. The LC operation was performed on a Cosmosil 5 C18-AR (4.6 × 150 mm) reversed-phase column, using a mobile phase composed of solvent A ¼ 0.1 M NH₄OAc (0.05% TAF) and solvent B ¼ ACN. A gradient elution protocol was adopted as follows: 20–30% B in 10 min, 30% B in 10 min, and 30–155% B in 10 min, flow rate 1 mL/min, detection at 280 nm.

Coumarins

The coumarins are the largest class of 1-benzopyran derivatives that are found mainly in higher plants. HPLC-PDA can be used successfully in the analysis of various phenolic compounds, including coumarins, because of the presence of significant amounts of chromophores in these molecules. The HPLC-PDA determination of coumarins, where absorption spectra are registered with a PDA detector, provides useful information about the identity of the molecule including oxidation pattern. The retention time together with the UV spectrum of individual peaks can be considered characteristic, and can easily be used to detect known coumarins in a crude extract. The coupling of MS to LC-PDA provides further structural information that is helpful for on-line identification of individual coumarins in any crude extract. Various coumarins together with other oxygen heterocyclic compounds, e.g., psoralens and polymethoxylated flavones, present in the nonvolatile residue of the citrus essential oils of mandarin, sweet orange, bitter orange, bergamot, and grapefruit, were analyzed by atmospheric pressure ionization (API) LC-MS system equipped with an APCI probe in positive ion mode.^[27] Recording MS spectra at different voltages provided information on molecular weight as well as fragment ions, and this allowed the identification of the main components in the extracts. In this study, cold-pressed citrus oils were analyzed by a Shimadzu LC system coupled with UV and MS detector with an APCI interface. The LC separation was carried out on a C18 Pinnacle column (250 × 4.6 mm, 5 mm), eluted isocratically or using a gradient at a flow rate of 1 mL/min with the solvent mixture: solvent A (THF:ACN:MeOH: water¼415:5:22:58) and solvent B (100% ACN). As coumarins are UV-absorbing compounds, they could be detected at 315 nm. The

MS acquisition conditions were as follows: probe high voltage, 4 kV; APCI temperature, 400°C; nebulizing gas (N₂) flow rate, 2.5 L/min; curved desolvation line (CDL) voltage, 25.5 V; CDL temperature, 230°C; deflector voltage, 25 and 60 V; and acquisition mode SCAN, 50–500 m/z.

Carotenoids

This group of natural products includes the hydrocarbons (carotenes) and their oxygenated derivatives (xanthophylls). LC-TLS has been applied successfully for the determination of carotenoids in four marine phytoplankton species, and a good degree of separation of diadinoxanthin, diatoxanthin, and other carotenoids has been achieved by isocratic HPLC elution with a greater sensitivity and selectivity than UV detection. This technique has allowed the monitoring of the interconversion of diadinoxanthin to diatoxanthin, and changes of other carotenoids under different light conditions.^[22] LC-TLS has also been found to be an ultrasensitive method for determination of b-carotene in fish oil-based supplementary drugs.^[28]

Essential oil and volatile components

GC-MS has been demonstrated to be a valuable analytical tool for the analysis of mainly nonpolar components and volatile natural products, e.g., mono- and sesquiterpenes. Chen *et al.*^[29] described a method using direct vaporization GC-MS to determine approx 130 volatile constituents in several Chinese medicinal herbs. They reported an efficient GC-MS method with EI for the separation and structure determination of the constituents in ether-extracted volatile oils of Chinese crude drugs, Jilin Ginseng, *Radix Aucklandiae*, and *Citrus tangerina* peels. The components, predominantly monoterpenes, of the volatile oil of the oleoresin of *Pestacia atlantica* var. *mutica* have been analyzed recently by GC-MS together with the application of on-line databases.^[30]

Saponins

Saponins are steroidal or triterpenoidal glycosides that occur widely in plant species of nearly 100 families.^[31] As saponins are highly polar compounds and difficult to volatilize, the application of GC-MS is mainly restricted to the analysis of aglycones known as sapogenins or saponins. Apart from just a few, saponins do not have chromophores that are essential for UV detection. Owing to the lack of chromophores in saponins, it is not helpful to use a UV or PDA as the primary detection technique. An alternative primary detection technique, e.g., refractive index, could be used. Sometimes, precolumn derivatization of saponins can be used to attach a chromophore

that facilitates UV detection at higher wavelengths. Among the hyphenated techniques, LC-MS, LC-NMR, and CE-MS could be useful for the rapid initial screening of crude extracts or fraction for the presence of saponins. While in LC-MS analysis TSP interface is used most extensively in phytochemical analysis, saponins having more than three sugars cannot be analyzed using this interface. For larger saponins (MW > 800), CF-FAB or ES is the method of choice. A combination of matrix solid-phase dispersion extraction and LC-NMR-MS was applied in the rapid on-line identification of asterosaponins of the starfish *Asterias rubens*.^[23,24] The LC-NMR-MS provided structural information in one single chromatographic run and was suitable for saponins in the molecular mass range 1200–1400 amu. This technique also allowed semiquantitative LC-NMR measurements through methyl signals (Me-18 and Me-19) of the steroidal skeleton.

Dereplication

The discrimination between previously tested or recovered natural product extracts and isolated single components found therein is essential to decrease the screening costs by reducing the large collections of isolates that are then subject to further detailed evaluation. Bioassay guided natural product isolation often leads to already known compounds of limited, or no chemical or pharmacological interest. Hence, appropriate methods that can distinguish at an early stage novel rather than known or already isolated natural compounds are essential for modern cost-effective natural product research. Dereplication strategies employ a combination of separation science, spectroscopic detection technologies, and on-line database searching. Thus, the combination of HPLC with structurally informative spectroscopic detection techniques, e.g., PDA, MS, and NMR, could allow crude extracts or fractions to be screened not just for biological activity but also for structural classes. To perform an efficient screening of extracts, both biological assays and HPLC analysis with various detection methods are used. Techniques such as HPLC coupled with UV photodiode array detection (LC-DAD-UV) and with mass spectrometry (LC-MS or LC-MS-MS) provide a large number of on-line analytical data of extract ingredients prior to isolation. The combination of HPLC coupled to NMR (LC-NMR) represents a powerful complement to LCUV-MS screening. These hyphenated techniques allow a rapid determination of known substances with only a small amount of source material.

LC-MS-MS spectra are generally reproducible. Therefore, the MS-MS databases of natural products can be used for dereplication purposes. For automated on-line dereplication purposes, Q-DIS/MARLINTM is one of the comprehensive and powerful analytical knowledge platforms available today, which is ideally suited for natural product dereplications. It permits quick identification of novel chemical classes based on LC-MS data. Q-DIS/MARLINTM is also perfect to automatically validate proposed chemical structures from combinatorial chemistry experiments of LC-MS data. Most of the dereplication protocols available to date for natural product analysis predominantly apply LC-PDA-MS. The LC-NMR, despite being able to provide more meaningful structural information, has achieved limited success owing to the lack of sensitivity, the dearth of general access to high-field NMR instruments, and the cost associated with the use of deuterated solvents.

Chemical fingerprinting and quality control of herbal medicine

The use of hyphenated techniques, e.g., LC-MS, CE-MS, LC-NMR, or LC-NMR-MS, in chemical fingerprinting analysis for quality control and standardization of medicinal herbs has attracted immense interest in recent years. Generally, in the context of drug analysis, fingerprinting method is used to highlight the profiles of the sample matrix, which is often sufficient to provide indications of the source and method of preparation. In herbal medicines, the profile depends not only on the preparation processes but also on the quality of the crude herb source material. The quality of the same herb can vary considerably depending on the geographic origins, sources, harvest times, and so on. The uniformity and stability of the chemical profiles thus represent the quality of the raw herbs. In both good agricultural practice (GAP) and good manufacturing practice (GMP), fingerprinting analysis is used to appraise the quality of the herbal material. In this process, the fundamental objective is to develop links between marker compound-based chromatographic or spectroscopic profiles and the efficacy of herbal products. Thin layer chromatography (TLC) has been the most widely used classical method for fingerprinting analysis in Chinese medicines. In the chemical fingerprinting method, wherever possible, the bioactive compounds or important chemical marker compounds are identified to allow consistent batch-to-batch fingerprinting analysis. For example, in the analysis of valerian (*Valeriana officinalis*) and feverfew (*Tanacetum parthenium*), the two marker compounds are valerenic acid and acetoxyvalerenic acid in the

former case, and parthenolide and sesquiterpene lactones in the latter.^[32] GC-MS or LC-MS can be used to detect and confirm the identity of these trace marker compounds. ESI technique was used in the HPLCMS-based detailed chemical fingerprinting of danshen, sanqi, and ginkgo. In fingerprinting analysis, it is imperative to optimize all laboratory instrumentations and methodology to avoid any artifacts in the results. The relative intensity of the peaks is important, and chromatographic fingerprints must be specific for the substance being analyzed. Hence, it is necessary to check fingerprints obtained from related botanical products and known adulterants to ensure that the method developed can distinguish true from false identifications. Several analytical protocols based on LC-MS fingerprinting have been developed and integrated into a high-throughput analytical program incorporating standard methods, template structure determination, and structural libraries. For example, LC-MS was used to characterize mixtures of taxanes from *Taxus brevifolia* extracts and to develop a taxane database. The sensitivity of the currently available hyphenated techniques permits minimum sample preparation, thus saving analysis time and reducing unnecessary degradation of the components.

Medicinal properties of herbs used in traditional systems of medicine, e.g., traditional Chinese medicine or Ayurveda, are attributed to the presence of various types of biologically active molecules. Any variation, either qualitative or quantitative, in the chemical profile of the herb can lead to the total loss of medicinal properties, decreased potency, or even increased toxicity. Therefore, it is essential, for quality control purposes, to ascertain the presence of certain molecules in the herbal preparation or extract, and also to determine the quantity of each of the active principles by applying a suitable method, which allows on-line detection of molecules present in the herbal extract. TLC or paper chromatography used to be the method of choice for the quality control of most of the ancient herbal medicines. Nowadays, with the advent of modern hyphenated techniques, it is possible to obtain comprehensive chemical profiles of herbal medicine preparations or extracts. GC-MS and LC-MS are now being used quite extensively for direct on-line analysis of components present in the herbal preparations and for ensuring the quality of the herb. These techniques have been used in the traditional Chinese medicine.^[33]

The mass spectra of various components present in the extracts of Chinese medicine have been obtained on-line from the LC-MS run and matched with known

standards for structural confirmation. Integrated MS databases have also been useful for identification of these compounds. In this way, GC-MS, LC-MS, and MS-MS fingerprinting profiles of the active ingredients of various Chinese herbal extracts have been obtained, and information has been stored in the form of an electronic database, which can be used for routine comparison of chemical profiles of individual herb extracts for quality control purposes. The GC or LC retention time and mass spectral data are reproducible, provided the chromatographic and spectroscopic conditions are kept constant. LC-NMR and LC-NMR MS have also been used to this purpose. A simple protocol for the chemical fingerprinting of *Ephedra* using HPLC-PDA has been recently described.^[34] *Ephedra sinica* (family: Ephedraceae), known as “ma huang,” is one of the oldest medicinal herbs used in traditional Chinese medicine. In the West, dietary supplements containing *E. sinica* have emerged as one of the top selling weight loss and endurance enhancing products used by over a million consumers.

Chemotaxonomy

Chemical taxonomy or chemotaxonomy is based on the principle that the presence of certain secondary metabolites is dictated by various enzymes involved in the biosynthesis of these compounds. These enzymes are strictly related to the genetic make-up of the organism. Hence, chemical profiling of these secondary metabolites, either by complete isolation and identification, or by separation and on-line identification using modern hyphenated techniques, could provide useful information with regard to the taxonomic or even phylogenetic relationships among various species. Introduction of hyphenated techniques in chemotaxonomic work can reduce the time and cost considerably by allowing on-line detection and identification of secondary metabolites present in extracts. Kite *et al.*^[25] described the application of GC-MS in the chemotaxonomic studies based on quinolizidine alkaloid profile in legumes. Using GCMS, it was possible to obtain data on the quinolizidine alkaloids of less readily available taxa by analyzing crude extracts made from small fragments of herbarium specimens, and thus compile a well-founded knowledge base on the distribution of such compounds in various species of legumes. On the basis of this distribution pattern of quinolizidine alkaloids, various chemotaxonomic inferences could be made. For example, from the GC-MS data analysis, it was observed that *Poecilanthe* contained quinolizidine alkaloids, and the particular combination of structures present suggested a similarity with members of

Brongniartieae.^[25]

Acceptable HPLC separation using a reversed-phase C18 column eluting a gradient of ACN–water or MeOH–water mixture could be achieved for flavonoids and other phenolic compounds. LC-MS was also found to be useful in chemotaxonomic studies based on flavonoid profiles in legumes. Both ES and APCI sources could ionize flavonoids in these mobile phases, and acceptable ionization could be achieved in both positive and negative modes to yield [M + H]⁺ and [M - H]⁻ ions, respectively. This technique allowed the analysis of various crude aqueous methanolic extracts of leaves or seeds of several legume species (without further 100 mL/500 mg of dry cells) and filtered, and the solvent was removed under vacuum to yield a dry extract. The residue was dissolved in acetone (100 mL) prior to injection into an HP1090M HPLC-PDA-MS system.

The separation of isoprenoid quinones in the extracts was carried out using an Intersil ODS-2 (1.5 ± 250 mm) column eluted isocratically with MeOH–isopropyl alcohol (7:3 v/v) at a flow rate of 0.11 mL/min. For postcolumn mixing of matrix and splitting, a solution of 6% *m*-nitrobenzyl alcohol in MeOH was used as a matrix and mixed with HPLC eluent at 1 mL/hour. The solution was split at a ratio of 25:1. On-line MS analysis was performed on a JEOL JMS-SX 102 mass spectrometer equipped with a Frit-FAB ion source and a FAB gun. Xe₊ was employed as a primary beam at 10 mA of emission current.

Metabolomics

The term “metabolome” refers to the entire complement of low molecular weight metabolites inside a biological cell, and is also used to describe the observable chemical profile or fingerprint of the metabolites in whole tissue.^[35] The metabolomes represent the life history of an individual organism, including age and environmental factors such as soil type, moisture content, temperature, and stress factors. The study involving the detailed analysis of these metabolomes is referred to as “metabolomics,” which is a newly emerging area in natural product research in the postgenome era. The aim of metabolomics, for example, plant metabolomics, is to provide a better understanding of metabolic or other physiological phenotypes through global genome-related technology. In metabolomics, nontargeted metabolite profiling and linkage of these profiles to genotypes or transcript profiles are regarded as the key issues.^[36] The metabolite profiling,

without the isolation of individual metabolites, requires sophisticated high-throughput analytical techniques, e.g, various types of hyphenated techniques. A typical example of metabolomic study can be demonstrated from the metabolite profiling, which is the first trial of a metabolomic approach of an anthocyanin chemotype, in red and green forms of *Perilla frutescens* using LC-PDA-MS, CE for anion analysis and LC for amino acid analysis.^[35] In addition, studies on cell-specific anthocyanin accumulation and localization of anthocyanidin synthase, and gene expression using mRNA differential display of two chemo-varietal forms of *P. frutescens*, were also carried out.

CONCLUSION

The technique developed from the coupling of a separation technique and an on-line spectroscopic detection technology is known as hyphenated technique. The remarkable improvements in hyphenated analytical methods over the last two decades have significantly broadened their applications in the analysis of biomaterials, especially natural products. In this article, recent advances in the applications of various hyphenated techniques, e.g., GC-MS, LC-MS, LC-FTIR, LC-NMR, CE-MS, etc. in the context of preisolation analyses of crude extracts or fraction from various natural sources, isolation and on-line detection of natural products, chemotaxonomic studies, chemical fingerprinting, quality control of herbal products, dereplication of natural products, and metabolomic studies are discussed with appropriate examples. Particular emphasis is given on the hyphenated techniques that involve LC as the separation tool.

REFERENCES

- Wilson ID, Brinkman UA. Hyphenation and hypernation: the practice and prospects of multiple hyphenation. *J Chromatogr A* 2003;1000:325-56.
- Wolfender JL, Ndjoko K, Hostettmann K. LC/NMR in natural products chemistry. *Curr Org Chem* 1998;2:575-96.
- Wolfender JL, Rodriguez S, Hostettmann K. Liquid chromatography coupled to mass spectrometry and nuclear magnetic resonance spectroscopy for the screening of plant constituents. *J Chromatogr A* 1998;794:299-316.
- Huber L, George SA. Diode Array Detection in HPLC. New York: Merce-Dekker; 1993.
- Niessen WM, Tinke AP. Liquid chromatography-mass spectrometry, general principles and instrumentation. *J Chromatogr A* 1995;703: 37-57.
- Niessen WM. Liquid chromatography-Mass spectrometry. 2nd ed. New York: Dekker; 1999
- Albert K. On-line use of NMR detection in separation chemistry. *J Chromatogr A* 1995;703:123-47.
- Lindon JC, Nicholson JK, Sidelmann UG, Wilson ID. Directly coupled HPLC-NMR and its application to drug metabolism. *Drug Metab Rev* 1997;29:707-46.
- Sudmeier JL, Gunther UL, Albert K, Bachovchin WW. Sensitivity optimisation in continuous-flow FTNMR. *J Magn Reson A* 1996;118:145-56.
- Wolfender JL, Hostettmann K, Abe F, Nagao T, Okabe H, Yamauchi T. Liquid chromatography combined with thermospray and continuous-flow fast atom bombardment mass spectrometry of glycosides in crude plant extract. *J Chromatogr A* 1995;712:155-68.
- Bringmann G, Messer K, Wohlfarth M, Kraus J, Dumbuya K, Ruckert, M. HPLC-CD on-line coupling in combination with HPLC-NMR and HPLC-MS/MS for the determination of the full absolute stereostructure of new metabolites in plant extracts. *Anal Chem* 1999;71:2678-86.
- Albert K. On-line LC-NMR and Related Techniques. London: Wiley; 2002.
- Jinno K. Basics and applications of hyphenated-detection system in HPLC: Part III—hyphenated techniques in HPLC. *Pharm Stage* 2001;1:110-31.
- Jinno K. Basics and applications of hyphenated-detection system in HPLC: Part II—detection systems in HPLC. *Pharm Stage* 2001;1: 74-80.
- Jinno K. Basics and applications of hyphenated-detection system in HPLC: Part I—Basics and applications in HPLC. *Pharm Stage* 2001;1:81-94.
- Jinno K. Infrared Detect, in *Encyclopedia of Chromatography*. In: Cazes J, Editor. New York, USA: Marcel Dekker; 2001
- Jinno K, Fujimoto C, Hirata Y. An interface for the combination of micro high performance liquid-chromatography and infrared spectrometry. *Appl Spectrosc* 1982;36:67-9.
- Bourne S, Haefner AM, Norton KL, Griffiths PR. Performance-characteristics of a real-time direct deposition gas-chromatography fourier-transform infrared spectrometry system. *Anal Chem* 1990;62:2448-52.
- Herderich M, Richling E, Roscher R, Schneider C, Schwab W, Humpf HU, *et al.* Application of atmospheric pressure ionisation HPLC-MS-MS for the analysis of natural products. *Chromatographia* 1997;45:127-32.
- Logar JK, Malej A, Franko M. Hyphenated high performance liquid chromatography-thermal lens spectrometry technique as a tool for investigations of xanthophyll cycle pigments in different taxonomic groups of marine phytoplankton. *Rev Sci Instrum* 2003;74:776-8.
- Dunayevskiy YM, Vouros P, Winter EA, Shippis GW, Carell T. Application of capillary electrophoresis-electrospray ionization spectrometry in the determination of molecular diversity. *Proc Natl Acad Sci* 1996;93:6152-7.
- Bernet P, Blaser D, Berger S, Schar M. Development of a robust capillary electrophoresis-mass spectrometer interface with a floating sheath liquid feed. *Chimica* 2004;58:196-9.
- Sandvoss M, Weltring A, Preiss A, Levsen K, Wuensch G. Combination of matrix solid-phase dispersion extraction and direct on-line liquid chromatography-nuclear magnetic resonance spectroscopy-tandem mass spectrometry as a new efficient approach for the rapid determination of natural products: application to the total asterosaponin fraction of the starfish *Asterias rubens*. *J Chromatogr A* 2001;917:75-86.
- Sandvoss M, Pham LH, Levsen K, Preiss A, Mugge C, Wuensch G. Isolation and structure elucidation of steroid oligoglycosides from the starfish *Asterias rubens* by means of direct on-line LC-NMR-MS hyphenation and one- and two-dimensional NMR investigations. *Eur J Org Chem* 2000;7:1253-62.
- Kite GC, Veitch NC, Grayer RJ, Simmonds MS. The use of hyphenated techniques in comparative phytochemical studies of legumes. *Biochem Syst Ecol* 2003;31:813-43.
- Iwasa K, Kuribayashi A, Sugiura M, Moriyasu M, Lee DU, Wiegrebe W. LC-NMR and LC-MS analysis of 2,3,10,11-oxygenated protoberberine metabolites in *Corydalis* cell cultures. *Phytochemistry* 2003;64:1229-38.
- Dugo P, Mondello L, Dugo L, Stancanelli R, Dugo G. LC-MS for the

- identification of oxygen heterocyclic compounds in citrus essential oils. *J Pharm Biomed Anal* 2000;24:147-54.
28. Luterotti S, Franko M, Bicanic D. Ultrasensitive determination of b-carotene in fish oil based supplementary drugs by HPLC-TLS. *J Pharm Biomed Anal* 1999;21:901-9.
 29. Chen Y, Li Z, Xue D, Qi L. Determination of volatile constituents of Chinese medicinal herbs by direct vaporization capillary gas-chromatography mass-spectrometry. *Anal Chem* 1987;59:744-8.
 30. Delazar A, Reid RC, Sarker SD. GC-MS analysis of essential oil of the oleoresin from *Pistacia atlantica* var *mutica*. *Chem Nat Compounds* 2004;40:24-7.
 31. Kumazawa S, Hamasaka T, Nakayama T. Antioxidant activity of propolis of various geographical origins. *Food Chem* 2004;84:329-39.
 32. Cai Z, Lee FS, Wang XR, Yu WJ. A capsule review of recent studies on the application of mass spectrometry in the analysis of Chinese medicinal herbs. *J Mass Spectrom* 2002;37:1013-24.
 33. Schaneberg BT, Crockett S, Bedir E, Khan IA. The role of chemical fingerprinting: application to *Ephedra*. *Phytochemistry* 2003;62:911-8.
 34. Ducrey B, Wolfender JL, Marston A, Hostettmann K. Analysis of flavonol glycosides of thirteen *Epilobium* species (Onagraceae) by LC-UV and thermospray LC-MS. *Phytochemistry* 1995;38:129-37.
 35. Ott KH, Aranibar N, Singh B, Stockton GW. Metabolomics classifies pathways affected by bioactive compounds. Artificial neural network classification of NMR spectra of plant extracts. *Phytochemistry* 2003;62:971-85.
 36. Yamazaki M, Nakajima J, Yamanashi M, Sugiyama M, Makita Y, Springob K, *et al.* Metabolomics and differential gene expression in anthocyanin chemo-variatal forms of *Perilla frutescens*. *Phytochemistry* 2003;62:987-95.

Source of Support: Nil, **Conflict of Interest:** None declared.

Author Help: Online submission of the manuscripts

Articles can be submitted online from <http://www.journalonweb.com>. For online submission, the articles should be prepared in two files (first page file and article file). Images should be submitted separately.

- 1) **First Page File:**
Prepare the title page, covering letter, acknowledgement etc. using a word processor program. All information related to your identity should be included here. Use text/rtf/doc/pdf files. Do not zip the files.
- 2) **Article File:**
The main text of the article, beginning with the Abstract to References (including tables) should be in this file. Do not include any information (such as acknowledgement, your names in page headers etc.) in this file. Use text/rtf/doc/pdf files. Do not zip the files. Limit the file size to 1024 kb. Do not incorporate images in the file. If file size is large, graphs can be submitted separately as images, without their being incorporated in the article file. This will reduce the size of the file.
- 3) **Images:**
Submit good quality color images. Each image should be less than **2048 kb (2 MB)** in size. The size of the image can be reduced by decreasing the actual height and width of the images (keep up to about 6 inches and up to about 1800 x 1200 pixels). JPEG is the most suitable file format. The image quality should be good enough to judge the scientific value of the image. For the purpose of printing, always retain a good quality, high resolution image. This high resolution image should be sent to the editorial office at the time of sending a revised article.
- 4) **Legends:**
Legends for the figures/images should be included at the end of the article file.